

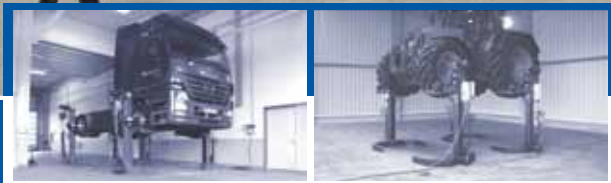

# Mobile Wheel Engaging Column Lifts

Models: RGE • RGE-GPGU • MCL • RGA



Lifting Technology



For vans, trucks, buses and special purpose vehicles



# Wheel Engaging Lift for Trucks and Buses

## Model: RGE



### Lifting system

Hardened stainless steel screw with low friction recirculating ball nut. Splash proof and dirt repellant design giving long life and low maintenance.

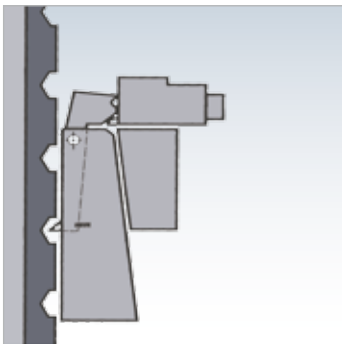

### Utmost safety

Independent locking device acting directly between column and carriage.



## Supplied Equipment

- ▶ Four single mobile columns with controls at each column
- ▶ Splash-proof power supply unit, including 10 m long connection cable and a connecting cable for powering the entire lift, with main switch (On/Off), universally connectable to each column of the system
- ▶ Three connecting cables, 10 m long each with plug and socket
- ▶ One mechanical dolly, movable on two wheels
- ▶ Lifting carriage with fixed wheel engaging forks
- ▶ Electronic synchronisation and safety monitoring as standard
- ▶ Low-friction recirculating ball nut and screw (efficiency over 90 %)
- ▶ Safety locking device independent of drive and screw
- ▶ Very easy emergency lowering function, in the event of a power failure, for example

## Description

- ▶ Five-year screw operation warranty
- ▶ Very long service life
- ▶ Limit stop, safety monitoring and displacement measurement through non-contact inductive sensors
- ▶ Selection of single columns (grouping) by keypress
- ▶ No master column owing to the mobile power supply unit, universally connectable to each column of the system
- ▶ Column wiring of utmost simplicity through ring line with end plug
- ▶ Good handling owing to the very slim design
- ▶ Low base frame height of 129 mm, thereby also allowing lifting of city buses
- ▶ 400 mm fork length for single wheel application
- ▶ Non-contact RPM sensing, bottom limit switching and nut monitoring through proximity switch, upper limit switching is software controlled
- ▶ EC type approval (CE)
- ▶ Electronic load monitoring



Remote Control TCNA 10-2  
up / down with emergency  
button (optionally available).

Slim design for easy manoeuvrability.



Convenient operation through  
rugged membrane keypad (up,  
down, single and group operation  
is possible).



No master column owing to the  
mobile power supply unit VELP.



## Technical Data

Maximum load capacity per column	7.5 t
Lifting range	1750 mm
Raising/lowering time	113 s
Net weight per column	452 kg
Motor power per column	1.5 kW
Control voltage	230/24 V
Supply voltage	3 x 400/230 V, 50 Hz
Fusing per column	4 A
Wheel size	8.25 to 12.00-20/12 R 22.5
System of protection	IP 54

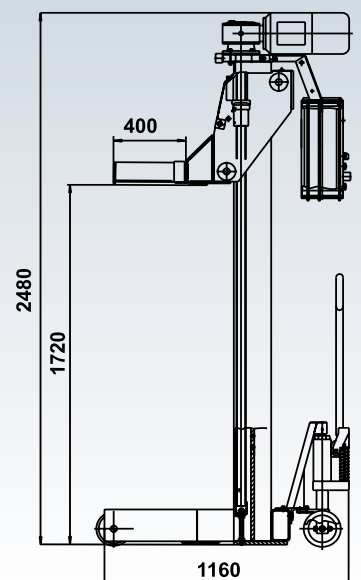
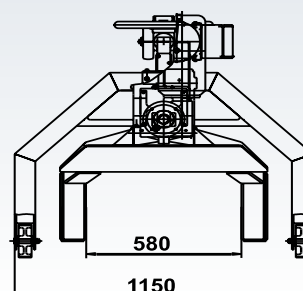

## Accessories for RGE

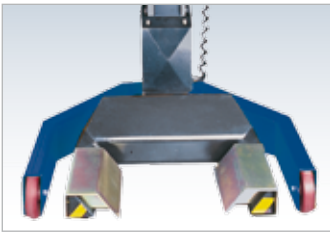

By fitting reduction sleeves vehicles with smaller wheel diameters can be accommodated.

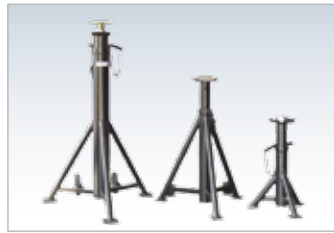

Stands		
1	AB 6-07,	470 - 795 mm
2	AB 6-12,	875 - 1395 mm
3	AB 6-20,	1200 - 1965 mm



- 1 **Adjustable support** SP 75
- 2 **Support plate** APV for stands
- 3 **Support disk** APR for stands



Remote control TCNA 10-2 with UP/DOWN and Emergency Off key function.



Hydraulic dolly; Model: MFP, for bolting to each column.

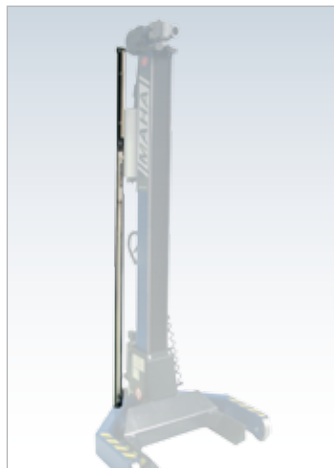

Illumination fitted to the side of the column.

### Further accessories, for example

- ▶ Single column RGE, including connecting cable with plug for assembling a six column system; without control box
- ▶ Carwash model RGE
- ▶ Custom control unit for connecting up to 12 wheel engaging columns
- ▶ Lifting carriage with fixed wheel engaging forks for special wheels
- ▶ Various power supply units
- ▶ Rechargeable battery torch
- ▶ 230 V shock-proof socket
- ▶ Dolly, mechanical, movable on wheels, Model: MFR-2
- ▶ Crossbar for accommodating semi-trailers
- ▶ Heavy duty castors at the base frame with plastic running surface

The RGE line maintains the successful line of MAHA wheel engaging lifts. This wheel engaging generation of lifts excels through its new electronic microprocessor controller which ensures the following functions:

- ▶ Synchronisation and communication between the columns
- ▶ Grouping
- ▶ Ball nut rupture monitoring
- ▶ Mains phase failure monitoring
- ▶ Automatic shutdown when hitting an obstruction
- ▶ Upper/bottom limit stop
- ▶ Monitoring and, if required, automatic changing of the phase sequence
- ▶ Electronic load monitoring



# Universal Lift for Forklifts, Rail Vehicles and Special Purpose Vehicles, Model: RGE-GPGU



Rail vehicles



Forklift



Municipal vehicles



Aircraft vehicles



Military vehicles

## Accessories

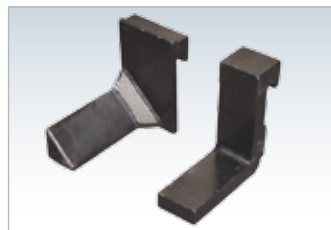

Various support forks.

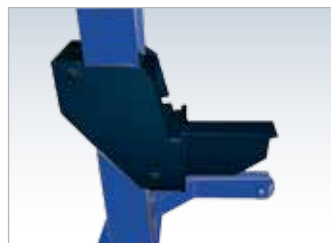

Special adapter for the rail vehicles, customized.



### Stands

1	AB 6-07,	470 - 795 mm
2	AB 6-12,	875 - 1395 mm
3	AB 6-20,	1200 - 1965 mm

Various other accessories are available!

### References:

Public transportation services in Potsdam (D), Chemnitz (D), Bern (CH), Stockholm (S), Göteborg (S), Wiener Linien, Wien (A), VAG Nürnberg (D), OEG Mannheim (D), Military (D), (S), (CH), (FIN), (GB), (A), (P)

## Supplied Equipment

- ▶ Two single mobile columns with control box at each column
- ▶ Splash-proof power supply unit, including 10 m long connection cable and a connecting cable for powering the entire lift, with main switch (On/Off), universally connectable to each column of the system
- ▶ One connecting cable, 10 m long with plug and socket
- ▶ One mechanical dolly, movable on two wheels
- ▶ Lifting carriage with movable flat, wheel engaging forks
- ▶ Electronic synchronisation and safety monitoring as standard
- ▶ Low-friction recirculating ball nut and screw (efficiency over 90 %)
- ▶ Safety locking device independent of drive and screw
- ▶ Very simple emergency lowering function, in the event of a power failure, for example

## Description

- ▶ See RGE!

This lift is specially suited for accepting forklifts and rail vehicles, custom solutions upon request!



Universal carriage

### Technical Data

Maximum load capacity per column	7.5 t
Lifting range	1750 mm
Raising/lowering time	113 s
Net weight per column	502 kg
Motor power per column	1.5 kW
Control voltage	230/24 V
Supply voltage	3 x 400/230 V, 50 Hz
Fusing per column	4 A
Wheel size	8.25 to 12.00-20/12 R 22.5
System of protection	IP 54

# Wheel Engaging Lift for Delivery Vans, Trucks and Buses

## Model: MCL



Owing to **radio control** no connecting cables between the columns are necessary. Thus no time is needed for wiring up the columns.



**Low-maintenance grease lubrication** within the carrying and safety nut ensures a supply of the lubricant for the trapezoidal lifting screw with long maintenance intervals.



**High stability** owing to low friction losses through roller suspended carriage.



### Supplied Equipment

- ▶ Four single mobile columns including splash-waterproof control box, each with a 10 m long connecting cable
- ▶ Electronic controller with functions UP/DOWN, emergency shutdown pushbutton, pushbuttons for single, joint and group operation
- ▶ One mechanical dolly movable, on two wheels
- ▶ Lifting carriage with fixed wheel engaging forks
- ▶ Electronic synchronisation and safety monitoring through wireless link
- ▶ Trapezoidal lifting screw with safety nut
- ▶ Drive unit with worm gear motor at the top
- ▶ Emergency lowering mechanism for manual lowering in the event of a power failure
- ▶ 230 V mains power socket

### Description

- With MCL line, MAHA offers a cost-effective, high-quality wheel engaging lift with wireless control of column operation
- ▶ Standard delivery 4 (MCL 22), 6 (MCL 33) or 8 columns (MCL 44)
  - ▶ Electronic control with single and group operation through wireless link
  - ▶ No master column and additional power supply unit
  - ▶ Non-contact limit, safety, and displacement measurement through inductive sensors
  - ▶ Low base frame height of 129 mm, thereby also allowing lifting of city buses
  - ▶ 400 mm fork length for single wheel application
  - ▶ Good handling through slim design
  - ▶ EC type approval (CE)



## Accessories



By fitting **reduction sleeves** vehicles with smaller wheel diameters can be accepted.



### Stands

1	AB 6-07,	470 - 795 mm
2	AB 6-12,	875 - 1395 mm
3	AB 6-20,	1200 - 1965 mm



Hydraulic dolly; Model: MFP for bolting to each column.



- 1 **Adjustable support SP 75**
- 2 **Support plate APV** for stands
- 3 **Support disk APR** for stands

### Further accessories, for example

- ▶ Cable remote control KFB2
- ▶ Support plate, round, pluggable or adjustable for stands
- ▶ Support plate, square, pluggable or adjustable for stands
- ▶ Crossbar for accommodating semi-trailers

## Technical Data

Lifting capacity per column	5.5 t
Lifting range	1750 mm
Lifting time	150 s
Supply voltage	3 x 400 V / 50 Hz
Fusing per column	5 A
Motor power	2.2 kW
Wheel size	8.25 to 12.00-20 /12 R 22.5
Weight per column	400 kg
System of protection	IP 54

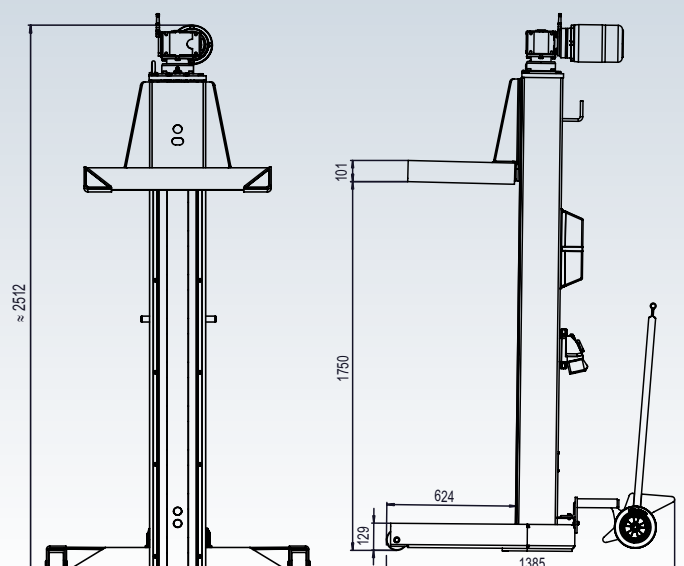
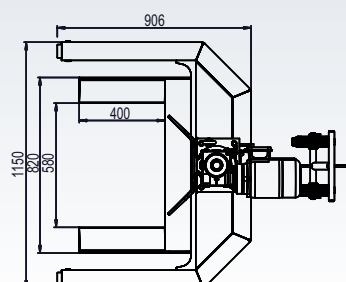



# Wheel Engaging Lift, battery-powered, for Trucks and Buses

## Model: RGA



### Lifting system

Hardened stainless steel screw with low friction recirculating ball nut. Splash proof and dirt repellent design giving long life and low maintenance.



Owing to **radio control** no connecting cables between the columns are necessary. Thus no time is needed for wiring up the columns.



The power supply through the **rechargeable battery pack** permits operation independent of any mains power supply and flexible utilisation without wiring work.



### Accessories

- ▶ Single column RGA, with hydraulic dolly
- ▶ Lifting carriage with fixed wheel engaging forks for custom wheels
- ▶ Cable remote control KFB2
- ▶ Reduction sleeves for smaller wheel diameters
- ▶ Stands
- ▶ Support plates, round, plug-gable or adjustable for stands
- ▶ Support plates, square, plug-gable or adjustable for stands
- ▶ Crossbar for accommodating semi-trailers

### Supplied Equipment

- ▶ Four single mobile columns incl. splash-proof control box and operating unit at each column
- ▶ Hydraulic dolly firmly bolted to each column
- ▶ Lifting carriage with fixed wheel engaging forks
- ▶ Automatic synchronisation as standard
- ▶ Powered through four batteries, 12 V each
- ▶ Electronic synchronisation and safety monitoring through wireless link
- ▶ Drive unit with worm gear motor at the top and low-wear and low-maintenance hardened precision screw with recirculating ball nut (efficiency over 90 %)
- ▶ Safety locking device independent of drive and screw
- ▶ Emergency lowering function, for mechanical lowering in the event of a power failure

### Description

- ▶ 5 year screw operation warranty, very long service life
- ▶ Limit stop, safety monitoring and displacement measurement through non-contact inductive sensors
- ▶ Selection of single columns (grouping) by keypress
- ▶ Non-contact RPM sensing, bottom limit switching and nut monitoring through proximity switch, upper limit switching is software controlled
- ▶ EC type approval (CE)

### Technical Data

Maximum load capacity per column	7.5 t
Lifting range	1750 mm
Raising/lowering time	113 s
Power supply voltage for charger	230 V
Control voltage	48 V
Strokes at full load (7500 kg)	20 strokes
Strokes at part load (3500 kg)	35 strokes
Motor power	1.5 kW
Wheel size	8.25 to 12.00-20/12 R 22.5
Weight per column	545 kg
Charging time	8 h

### Production Program:

Testing Technology for Cars, Trucks, Motorcycles, Tractors, Forklifts, Aircraft · Roller Brake Testers · Platform Brake Testers · Shock Absorber and Suspension Testers · Side-Slip Testers · Play Detectors · Roller Dynamometers for Performance and Function Testing · Speedometer Testers · Tachograph and Taximeter Testers · Axle and Wheel Load Scales · Scissors Lifts · Two- and Four-Post Lifts · In-Ground Lifts · Pit Jacks · Axle and Transmission Jacks · Mobile Column Lifts · Headlight Testers · Diesel Smoke Meters · Emission Testers for Petrol and Gas Engines · Sound Level Meters · Air Conditioning Service Equipment · Decelerometers · Closing Force Meters · Brake Fluid Testers · Complete Test Lanes for Cars and Trucks · Mobile Test Containers · Wheel Alignment Analysers · Wheel Balancers · Tire Changers.

**Additional Services:** Workshop Design and Planning · Training Seminars for Users and Service Technicians



**MAHA Maschinenbau Haldenwang GmbH & Co. KG.**  
**Hoyen 20 · 87490 Haldenwang · Germany**  
 Tel.: +49 (0)8374-585-0 · Fax: +49 (0)8374-585-497  
 Internet: www.maha.de · E-Mail: sales@maha.de



Certification of environmental management system

**ISO 14001:2004**



- ▶ MAHA U.K. Ltd. · Wisbech · Great Britain
- ▶ MAHA Ireland Ltd. · Dublin · Ireland
- ▶ MAHA España · Girona · Spain
- ▶ MAHA Polska · Tarnowskie Góry · Poland
- ▶ MAHA Russia · St. Petersburg · Russian Fed.
- ▶ MAHA France · Strasbourg · France
- ▶ Joint Venture Romaha · Belfast · Northern Ireland

- ▶ HETRA International AG · Zurich · Switzerland
- ▶ MAHA USA · Pinckard AL · USA
- ▶ MAHA Chile · Santiago · Chile
- ▶ MAHA China · Peking, Shanghai · China
- ▶ MAHA Japan · Tokyo · Japan (Rep. Office)
- ▶ MAHA Singapore · Singapore (Rep. Office)
- ▶ MAHA South Africa (Pty.) Ltd. · Johannesburg · South Africa